

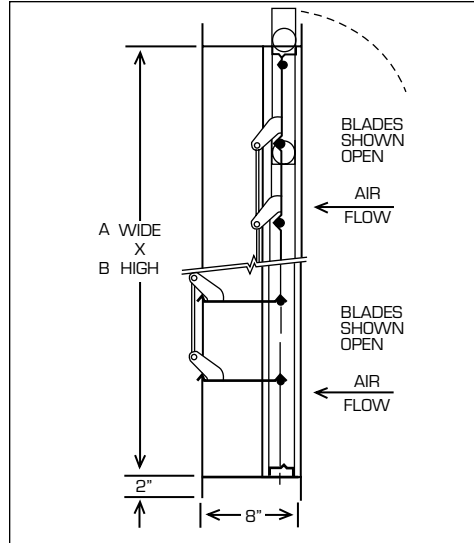

**CERTIFICATION & SUBMITTAL  
MODEL 3200  
Medium Duty Counter-Balanced Backdraft Dampers**



**MODEL 3202**



**MODEL 3202**

**STANDARD SPECIFICATIONS**

**OPTION**

- **FRAME:** 12 ga. galvanized steel channel with 14 ga. galvanized press formed steel sub frame.
- **BLADES:** 16 ga. galvanized steel with press formed "V" reinforcement.
- **COUNTERBALANCE ARMS:** 2" x 1/4" x 12" lg. hot rolled steel bar external to damper.
- **COUNTERWEIGHTS:** 2" dia hot rolled steel bar attached to counterbalance arms.
- **AXLES:** 1/2" dia. C1018 steel cadmium plated steel continuous rods.
- **BEARINGS:** 1/2" dia. I.D. ball bearings.
- **HARDWARE:** Plated steel center brackets; brass pivots; 5/16" plated steel linkage rod. Dual linkage on panels 31" to 48" wide.
- **CONSTRUCTION:** All welded. Units over 48" wide, dual panel.
- **FINISH:** Standard Mill.
- **MAXIMUM SIZE:** 72" x 60"
- **MINIMUM SIZE:** 12" x 8" Single Blade; 12" x 12" Multi Blade.
- **MAXIMUM VELOCITY:** 3500 F.P.M.
- **MAX. STATIC PRESSURE:** 4" W.G.
- **MAX. TEMPERATURE:** 250°F

- 06 Blade Edge seals.

**NOTES**

1. A & B are actual dimensions.
2. Dual counterweights on units 5 blades and over (i.e., 36" and over).
3. Dual linkage on panels over 30" wide.
4. Counterweights are located on left-hand side when facing air leaving side.
5. Down Flow Models not available. Up Flow Model 3212 not shown.
6. Counterweights must be field adjusted to system pressure.