

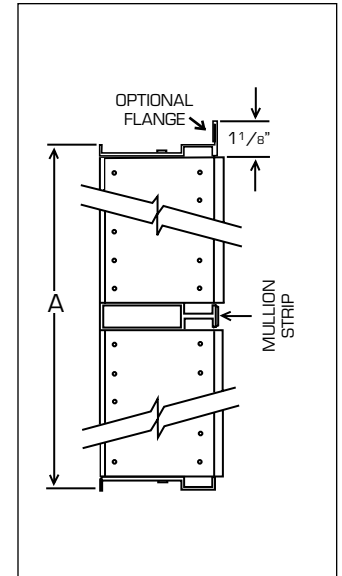

**CERTIFICATION & SUBMITTAL
MODEL 4685 FABRICATED LOUVER
Insulated Blade @ 90°**

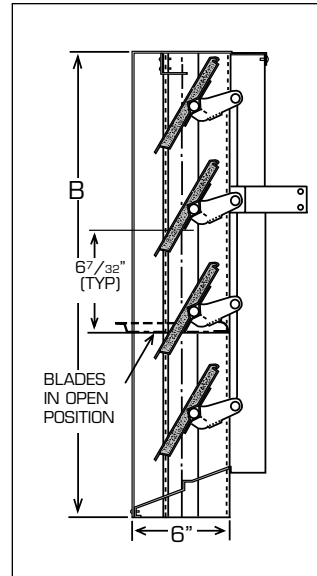
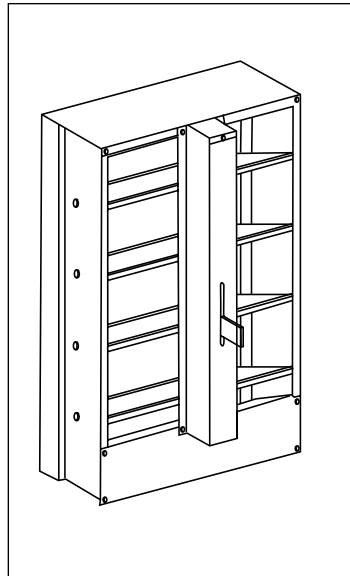
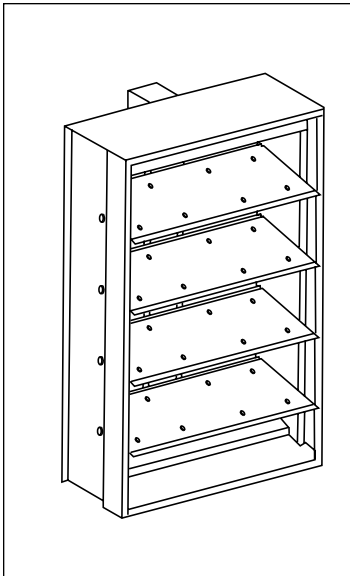

STANDARD SPECIFICATIONS

- **FRAME:** 18 gauge galvanized steel head and sill
14 gauge galvanized steel jambs.
- **BLADES:** 18 gauge galvanized press formed steel.
18 gauge galvanized steel liner.
- **INSULATION:** 1/2" Polyurethane foam between blade and liner, extending full length of each blade.
- **AXLES:** 1/2" diameter x 2" long plated steel rods.
- **BEARINGS:** 1/2" diameter Nylon bearings.
- **BLADE EDGE SEAL:** Extruded dual durometer Dyn-O-Grip.
- **SIDE SEALS:** Spring Stainless Steel.
- **HARDWARE:** Plated steel center brackets; brass pivots,
5/16" diameter plated steel linkage rod.
- **OPERATING ARM:** 14 gauge galvanized steel.
- **COVER CHANNEL:** 18 gauge galvanized steel.
- **BIRDSCREEN:** 19 gauge 1/2" x 1/2" galvanized steel
- **FINISH:** Standard Mill.
- **MAX. SINGLE SECTION:** 48" X 72"

OPTIONS

- 31 Flange.
- 32 Multiple Section.
- 34 Buck Frame (requires flanged louver).
- 35 Sill Extension.
- 40 Standard Screen in removable frame.
- 42 18 x 16 Mesh aluminum insect screen.
- 43 18 x 16 Mesh bronze insect screen.
- 44 1/2" x 1/2" x 16 gauge S.S. screen.
- 45 1/2" x 1/2" x .063 aluminum screen.
- 89 Sleeve.
- 90 Jackshaft.
- 92 Actuators.
- 95 Finishing.

NOTE: A and B are opening dimensions. Unless otherwise specified, louvers are made 1/4" undersize.

**PERFORMANCE DATA MODEL 4685
FABRICATED METAL LOUVER
Adjustable Blade @ 90°**

		A - WIDTH (In Inches)									
		12	16	29	24	28	32	36	40	44	48
B - HEIGHT (In Inches)	12	.59	.82	1.04	1.27	1.49	1.71	1.94	2.16	2.38	2.61
	.59	.59	.82	1.04	1.27	1.49	1.71	1.94	2.16	2.38	2.61
	20	1.03	1.41	1.80	2.19	2.57	2.96	3.35	3.73	4.12	4.51
	24	1.46	2.01	2.56	3.11	3.66	4.21	4.76	5.31	5.86	6.41
	28	1.46	2.01	2.56	3.11	3.66	4.21	4.76	5.31	5.86	6.41
	32	1.89	2.61	3.32	4.03	4.75	5.46	6.17	6.88	7.60	8.31
	36	2.33	3.20	4.08	4.95	5.83	6.71	7.58	8.46	9.33	10.21
	40	2.33	3.20	4.08	4.95	5.83	6.71	7.58	8.46	9.33	10.21
	44	2.76	3.80	4.84	5.88	6.92	7.95	8.99	10.03	11.07	12.11
	48	3.19	4.40	5.60	6.80	8.00	9.20	10.41	11.61	12.81	14.01
	52	3.19	4.40	5.60	6.80	8.00	9.20	10.41	11.61	12.81	14.01
	56	3.63	4.99	6.36	7.72	9.09	10.45	11.82	13.18	14.55	15.91
	60	3.63	4.99	6.36	7.72	9.09	10.45	11.82	13.18	14.55	15.91
	64	4.06	5.59	7.12	8.64	10.17	11.70	13.23	14.76	16.28	17.81
	68	4.49	6.18	7.87	9.57	11.26	12.95	14.64	16.33	18.02	19.71
74	4.49	6.18	7.87	9.57	11.26	12.95	14.64	16.33	18.02	19.71	

FREE AREA (Sq. Ft.)

PERFORMANCE NOTES:

1. Insulating "K" factor is .28.
2. "U" factor is .57 BTU per hour per square foot per degree F.
3. Leakage shall not exceed 1 CFM/FT² @ 25 MPH wind velocity or .5" S.P.W.G.
4. Pressure drop shall not exceed .05" S.P. @ 500 F.P.M.
5. It is possible for moisture to penetrate louvers with blades in full open position. For critical applications, drained ductwork or other means of drainage is recommended.