

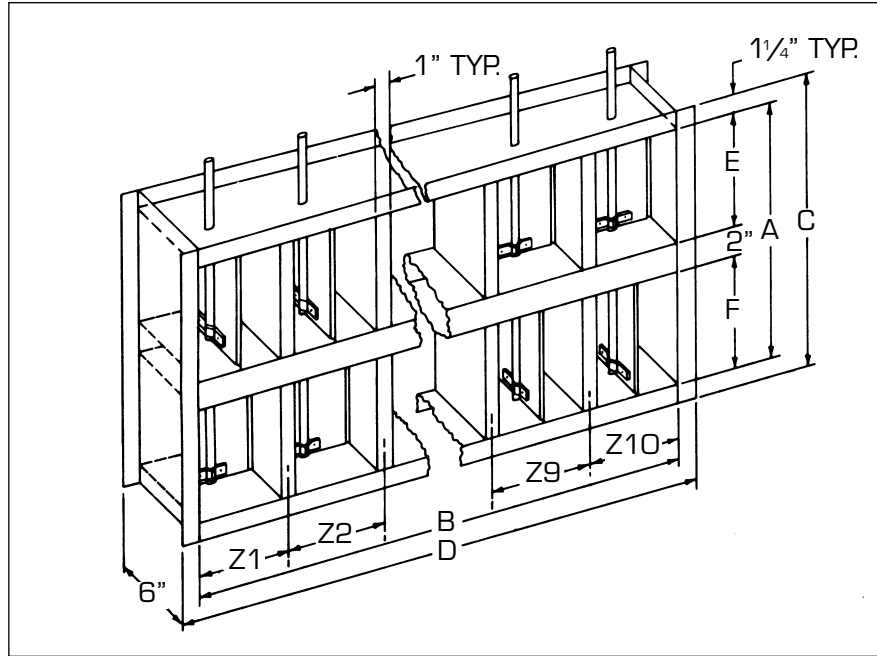

**CERTIFICATION & SUBMITTAL
MODEL 5100-04
Multi-zone Damper**



STANDARD SPECIFICATIONS

NOTES:

- **FRAME:** 18 gauge galvanized press formed steel.
- **BLADES:** 16 gauge galvanized steel with press formed "V" reinforcements.
- **AXLES:** 1/2" x 2" long plated steel rod.
- **BEARINGS:** 1/2" diameter self-lubricating porous bronze.
- **CONTROL RODS:** 1/2" diameter plated steel, full length. One per zone.
- **HARDWARE:** Plated steel center brackets, brass pivots, 1/4" or 5/16" dia. plated steel linkage rod.
- **CONSTRUCTION:** Welded frame; riveted hardware.
- **FINISH:** Standard Mill.

1. Parallel multi-blade operation when zone dimension exceeds 12". 12" and under will be single blade unless otherwise specified.
2. Zone dampers are manufactured to actual dimensions.

QTY.	OVERALL DIMENSIONS						ZONE DIMENSIONS										TAG	
	A	B	C	D	E	F	Z1	Z2	Z3	Z4	Z5	Z6	Z7	Z8	Z9	Z10		