

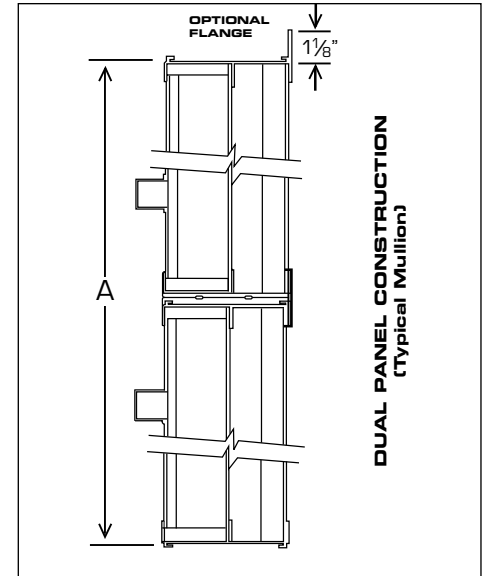

**CERTIFICATION & SUBMITTAL
MODEL 2200 ADJUST-O-VENT COMBINATION DAMPER/LOUVER
AUTOMATIC GRAVITY INTAKE**

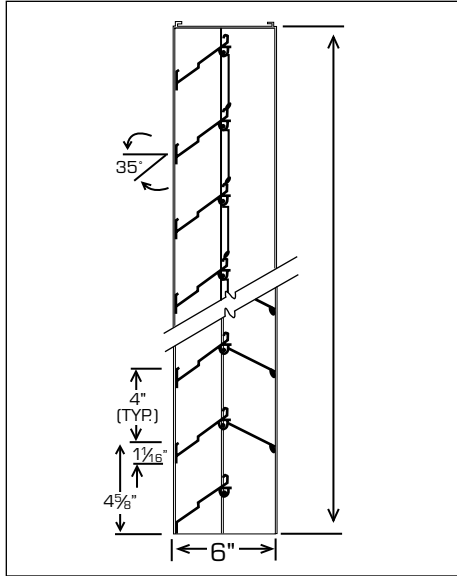

STANDARD SPECIFICATIONS

- **FRAME:** .080 6063T5 extruded aluminum.
- **BLADES:** .072 6063T5 extruded aluminum with full length pivoting.
- **BIRDSCREEN:** .051 X 3/4" diamond pattern expanded aluminum.
- **BLADE EDGE SEAL:** Vinyl gasketing extending full length of adjustable blades.
- **FINISH:** Standard Mill.
- **MAXIMUM SINGLE SECTION:** 60" x 96"
- **MINIMUM SIZE:** 12" x 12"
- **NOTE:**
 1. A and B are opening dimensions. Unless otherwise specified, louvers are made 1/4" undersize.
 2. It is possible that moisture will penetrate this louver during certain atmospheric conditions.

OPTIONS

- 31 Flange.
- 32 Multiple Section.
- 34 Buck Frame.
- 35 Sill Extension.
- 40 Standard Screen in removable frame.
- 42 18 x 16 Mesh aluminum insect screen.
- 43 18 x 16 Mesh bronze insect screen.
- 44 1/2" x 1/2" x 16 gauge S.S. screen.
- 45 1/2" x 1/2" x .063 aluminum screen.
- 89 Sleeve.

**PERFORMANCE DATA MODEL 2200
EXTRUDED ALUMINUM COMBINATION DAMPER/LOUVER
AUTOMATIC GRAVITY INTAKE**

FREE AREA CHART

		A - WIDTH (In Inches)												
		12	16	20	24	28	32	36	40	44	48	52	56	60
B - HEIGHT (In Inches)	12	.20	.28	.37	.46	.55	.63	.72	.81	.89	.98	1.07	1.15	1.24
	16	.40	.57	.74	.92	1.09	1.26	1.44	1.61	1.78	1.96	2.13	2.31	2.48
	20	.59	.85	1.11	1.38	1.64	1.90	2.16	2.42	2.68	2.94	3.20	3.46	3.72
	24	.79	1.14	1.49	1.83	2.18	2.53	2.88	3.22	3.57	3.92	4.26	4.61	4.96
	28	.99	1.42	1.86	2.29	2.73	3.16	3.59	4.03	4.46	4.90	5.33	5.76	6.20
	32	1.19	1.71	2.23	2.75	3.27	3.79	4.31	4.83	5.35	5.88	6.40	6.92	7.44
	36	1.39	1.99	2.60	3.21	3.82	4.42	5.03	5.64	6.25	6.85	7.46	8.07	8.68
	40	1.39	1.99	2.60	3.21	3.82	4.42	5.03	5.64	6.25	6.85	7.46	8.07	8.68
	44	1.58	2.28	2.97	3.67	4.36	5.06	5.75	6.45	7.14	7.83	8.53	9.22	9.92
	48	1.78	2.56	3.34	4.13	4.91	5.69	6.47	7.25	8.03	8.81	9.59	10.38	11.16
	52	1.98	2.85	3.72	4.58	5.45	6.32	7.19	8.06	8.92	9.79	10.68	11.53	12.40
	56	2.18	3.13	4.09	5.04	6.00	6.95	7.91	8.86	9.82	10.77	11.73	12.68	13.64
	60	2.38	3.42	4.46	5.50	6.54	7.58	8.63	9.67	10.71	11.75	12.79	13.83	14.88
	64	2.57	3.70	4.83	5.96	7.09	8.22	9.35	10.47	11.60	12.73	13.86	14.99	16.12
	68	2.77	3.99	5.20	6.42	7.63	8.85	10.06	11.28	12.49	13.71	14.93	16.14	17.36
	72	2.97	4.27	5.57	6.88	8.18	9.48	10.78	12.09	13.39	14.69	15.99	17.29	18.60
76	3.17	4.56	5.95	7.34	8.72	10.11	11.50	12.89	14.28	15.67	17.06	18.45	19.84	
80	3.37	4.84	6.32	7.79	9.27	10.74	12.22	13.70	15.17	16.65	18.12	19.60	21.07	
84	3.56	5.13	6.69	8.25	9.81	11.38	12.94	14.50	16.06	17.63	19.19	20.75	22.31	
88	3.76	5.41	7.06	8.71	10.36	12.01	13.66	15.31	16.96	18.61	20.26	21.90	23.55	
92	3.96	5.70	7.43	9.17	10.90	12.64	14.38	16.11	17.85	19.59	21.32	23.06	24.79	
96	3.96	5.70	7.43	9.17	10.90	12.64	14.38	16.11	17.85	19.59	21.32	23.06	24.79	

FREE AREA (Sq. Ft.)

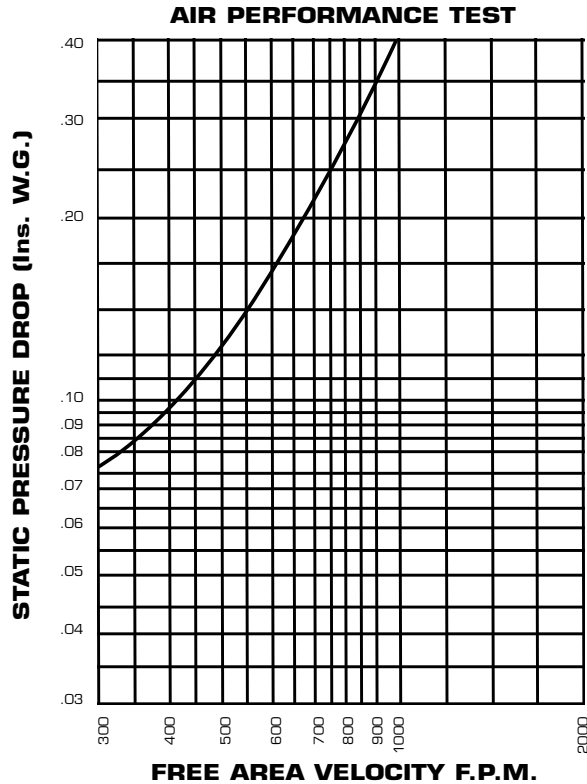

TEST UNIT SIZE 48" X 48" (15 Min. Duration)

Data shown includes the effect of .051 x 3/4" diamond pattern aluminum birdscreen. Graphs are corrected to standard air density .075 lb. per cubic foot.

RECOMMENDED MAXIMUM INTAKE FREE AREA VELOCITY 500 F.P.M.